



Struttura: in legno multistrato con molleggio garantito da cinghie elastiche ad alta componente di caucciù. Preparazione della struttura sedile in poliuretano espanso a quote differenziate ad alta densità con sede concava per accogliere il cuscino migliorandone sofficià e durata. Braccioli e schienali rivestiti nella parte superiore con materiale termosensibile (Memory Foam). Ulteriore rivestimento in fibra termolegata traspirante accoppiata con tela di cotone bianca anallergica che conferisce morbidezza.

Cuscinatura: imbottitura cuscino schienale e sedile in piuma d'oca canalizzata (certificata Assopiuma, Etichetta Oro) con inserto centrale in poliuretano espanso a quote differenziate ad alta resilienza. Cuscini sedile completamente reversibili.

Sfoderabilità: cuscini sedile, cuscini schienale e struttura completamente sfoderabili in tutte le versioni (tessuto e pelle).

Basi: portanti in estruso di alluminio verniciato lucido anti-touch color Peltro.

Scivolanti in nylon.

N.B.: per agevolare la sfoderabilità e la consegna, i braccioli e gli schienali sono sfilabili dalla base tramite un sistema di innesto e sgancio rapido.

Structure: in multy-plywood with suspension provided by high-rubber-content elastic webbing. The seat structure is made of high resilience, variable-density polyurethane foam with a concave contour to cradle the cushion, maximizing softness and durability. The upper portion of the armrests and backrests is made of temperature sensitive Memory Foam. An additional casing in breathable heat-bonded fiber laminated to white hypoallergenic cotton fabric lends superior softness.

Cushions: channeled goose down (certified Assopiuma, Gold Label) padding for backrests and cushions with center insert in high resilience, variable-density polyurethane foam. Seat cushions are completely reversible.

Covers: seat cushions, backrest cushions and structure covers are completely removable in all versions (fabric and leather).

Bases: weight-bearing parts in extruded aluminium with polish, anti-fingerprint Pewter colour varnished.

Nylon slides.

N.B.: to facilitate transport and removal of covers, the armrests and backrests can be removed from the base through a system of quick set and release closures.

Gestell: Schichtholz mit Federung durch elastische Gurte mit hohem Kautschukinhalt. Aufbereitung der Sitzstruktur mit unterschiedlich dick geschäumtem, hochdichtem Polyurethan mit konkaver Sitzfläche, um das Sitzkissen aufzunehmen und den Sitz weicher und robuster zu machen. Arm- und Rückenlehnen am oberen Teil mit thermosensiblen Material bezogen (Memory Foam). Ein weiterer Bezug ist aus atmungsaktiver, thermofixierter Faser, kombiniert mit antiallergischem, weißem Baumwolltuch, das elastische Weichheit verleiht.

Kissen: Polsterung des Rücken- und Sitzkissens aus kanalisierten Gänsedaunen (Gold Label, zertifiziert von Assopiuma) mit zentraler Einlage aus unterschiedlich dickem, federndem hochdichtem Polyurethanschaum. Sitzkissen beidseitig verwendbar.

Abziehbarkeit: Sitz- und Rückenkissen, sowie Struktur in allen Varianten (Stoff- und Lederbezug) vollkommen abziehbar.

Grundgestell: Tragende Teile aus Aluminiumpressguss, zinnfarbig lackiert mit glänzendem Anti-Touch-Finish.

Gleitschutz aus Nylon.

N.B.: um das Abziehen und den Transport zu vereinfachen, sind Arm- und Rückenlehnen über ein praktisches, schnelles Stecksystem mit dem Grundgestell verbunden.

Structure : en bois contreplaqué, suspension assurée par des sangles élastiques à haute teneur en caoutchouc. Préparation de la structure d'assise en polyuréthane expansé à densité différenciée et haute densité, avec logement concave pour accueillir le coussin et en améliorer le moelleux et la durée. Accoudoirs et dossiers doublés de mousse thermosensible à mémoire de forme (Memory Foam) dans la partie supérieure. Second revêtement en fibre thermolée respirante, doublée de toile de coton blanc anallergique pour davantage de souplesse.

Coussins : rembourrage du coussin de dossier et d'assise en plume d'oise canalisée (certifiée Assopiuma, Étiquette Or) avec insert central en polyuréthane expansé à densité différenciée haute résilience. Coussins d'assise entièrement réversibles.

Déhoussage : coussins d'assise, coussins de dossier et structure entièrement déhoussables dans toutes les versions (tissu et cuir).

Bases : portantes en aluminium extrudé, peinture brillante anti-trace couleur Étain. Patins en nylon.

N.B. : pour faciliter le déhoussage et la livraison, les accoudoirs et les dossiers peuvent être démontables de la base grâce à un mécanisme d'enclenchement et déclenchement rapide.

POSIZIONE CUSCINO SCHIENALE CON O SENZA POGGIATESTA | BACKREST CUSHION POSITION WITH OR WITHOUT HEADREST

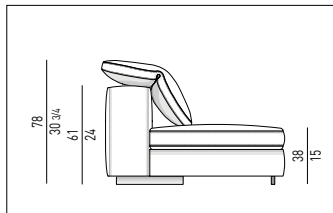

Grazie ad un particolare sistema di confezione, il cuscino presenta una piega sul dorso che fa sì che possa essere utilizzato su ambedue i lati, rispondendo a diverse funzionalità: morbidamente adagiato sullo schienale oppure sul bracciolo, o appoggiato al poggiatesta per un supporto ancora più confortevole.

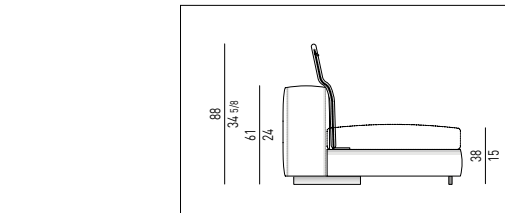

Another very defining characteristic of the Yang seating system is its reversible backrest cushion. The back fold allows it to be used on both sides, and in so doing has various functions: softly placed on the backrest or on the armrest, or on the headrest for added comfortable support.

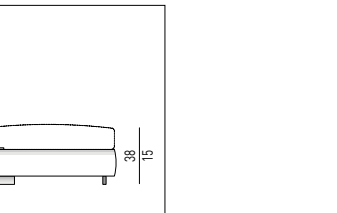

Dank der spezifischen Anfertigung, das Kissen verfügt über eine Falte auf der Rückseite, kann es beidseitig benutzt werden und mehrere Funktionen erfüllen: Es kann locker auf die Rückenlehne oder auf die Armlehne gelegt, oder an die Kopfstütze angelehnt werden, um den Komfort noch zu erhöhen.

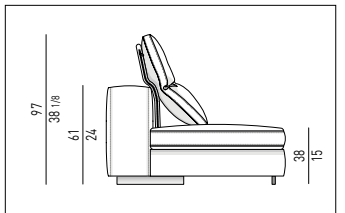

En raison de son système de confection, l'envers du coussin présente un pli permettant de l'utiliser de deux côtés, et de remplir différentes fonctions : il peut être doucement posé contre le dossier ou sur l'accoudoir, ou bien sur l'appui-tête pour en augmenter le confort.

ALTEZZE E PROFONDITÀ | HEIGHTS AND DEPTHS

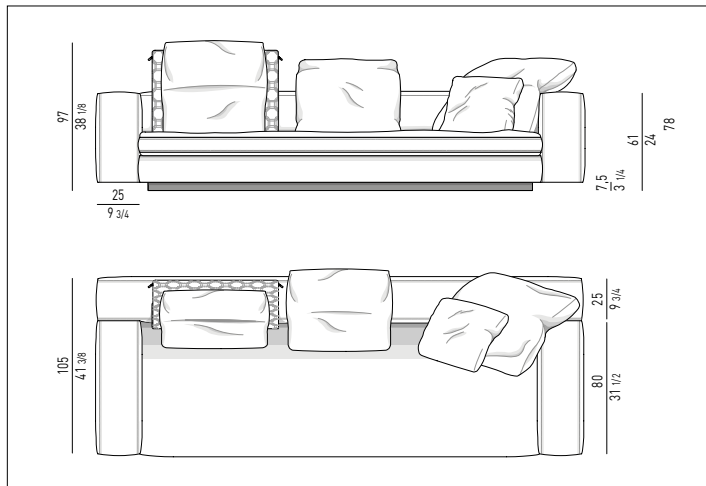

POSIZIONE BASI | BASES POSITION

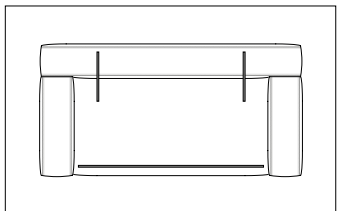

**FINITURA BASI
BASES FINISH**

ALLUMINIO | ALUMINUM

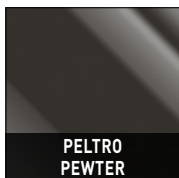

DIVANI | SOFAS

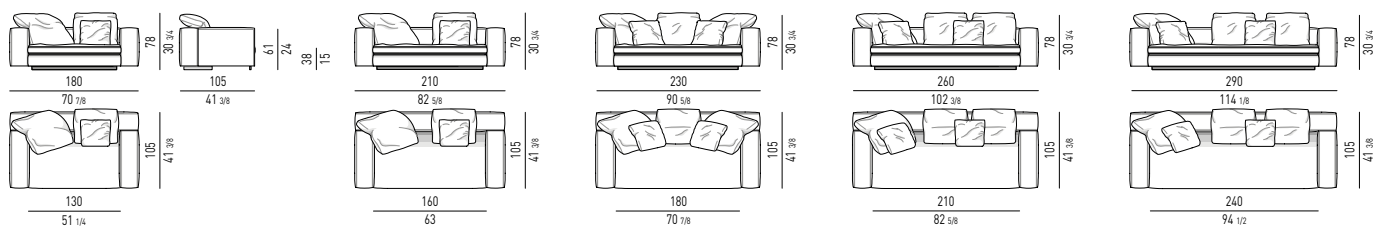

DIVANI COMPOSTI | COMPOSED SOFAS

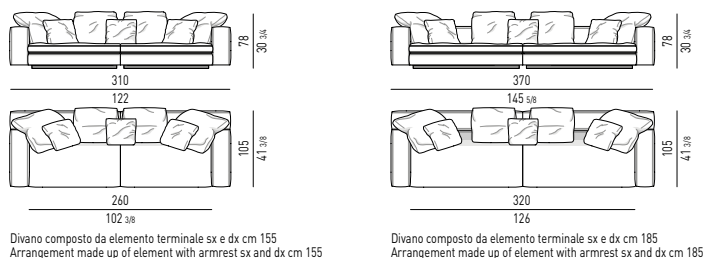

DIVANI-DAYBED | DAYBED-SOFAS

DIVANO-DAYBED CM 260 - SCHIENALE CM 180
DAYBED-SOFA CM 260 - BACKREST CM 180

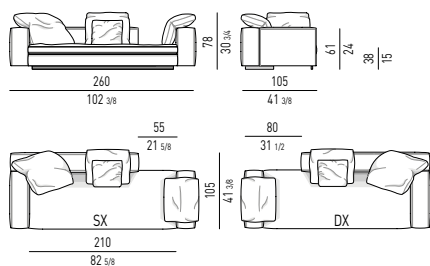

DIVANO-DAYBED CM 290 - SCHIENALE CM 185
DAYBED-SOFA CM 290 - BACKREST CM 185

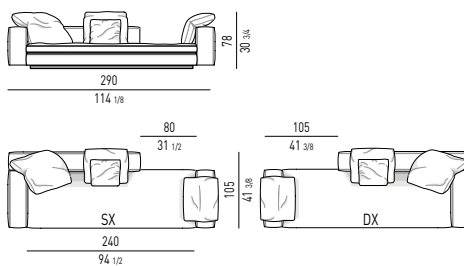

ELEMENTI DAYBED | DAYBED ELEMENTS

ELEMENTO DAYBED CM 185 - SCHIENALE CM 105
DAYBED ELEMENT CM 185 - BACKREST CM 105

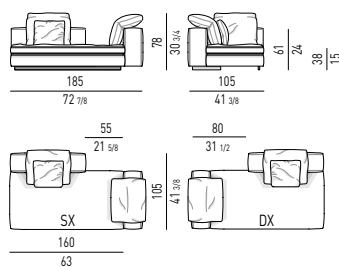

ELEMENTO DAYBED CM 235 - SCHIENALE CM 155
DAYBED ELEMENT CM 235 - BACKREST CM 155

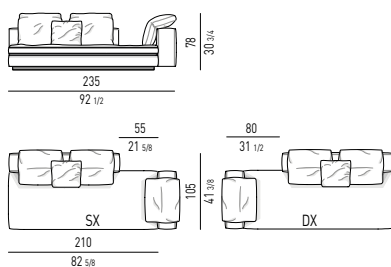

ELEMENTO DAYBED CM 265 - SCHIENALE CM 145
DAYBED ELEMENT CM 265 - BACKREST CM 145

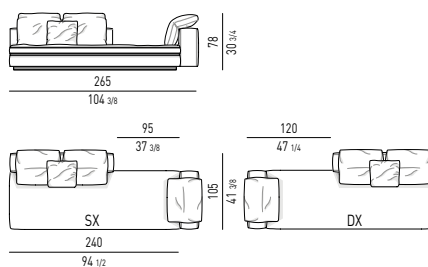

ELEMENTO DAYBED CM 265 - SCHIENALE CM 185
DAYBED ELEMENT CM 265 - BACKREST CM 185

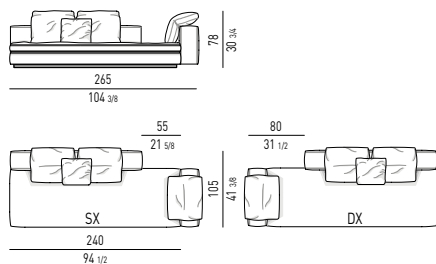

ELEMENTI TERMINALI | ELEMENTS WITH ONE ARMREST

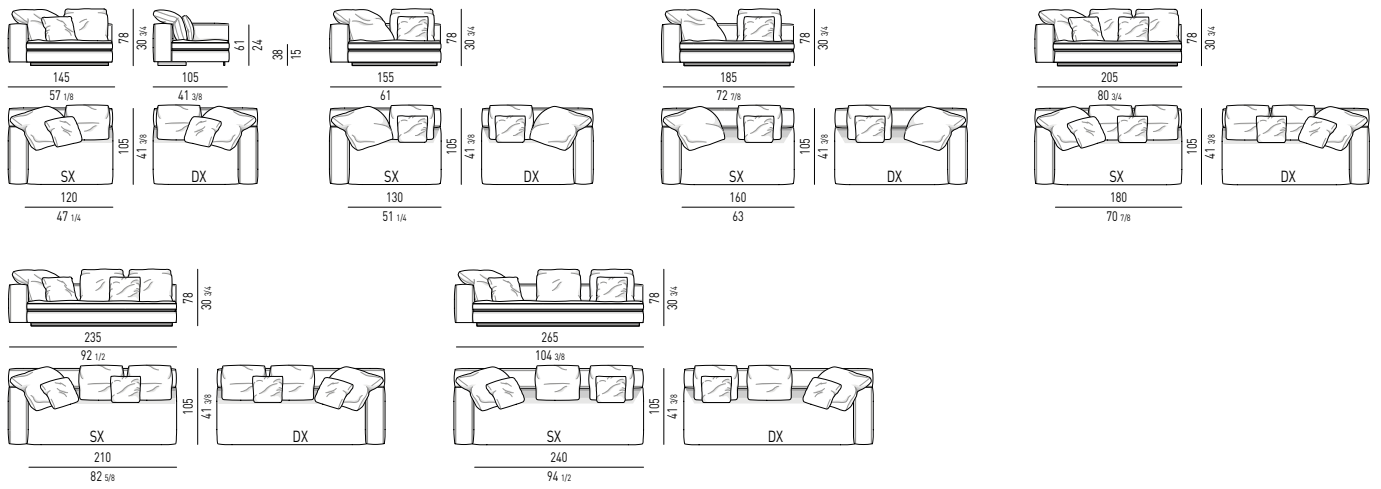

ELEMENTI TERMINALI PENISOLA | OPEN-END ELEMENTS WITH ARMREST

ELEMENTO TERMINALE PENISOLA CM 185 - SCHIENALE CM 105
OPEN-END ELEMENT WITH ARMREST CM 185 - BACKREST CM 105

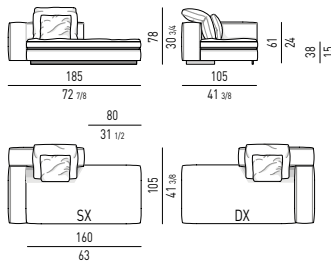

ELEMENTO TERMINALE PENISOLA CM 185 - SCHIENALE CM 130
OPEN-END ELEMENT WITH ARMREST CM 185 - BACKREST CM 130

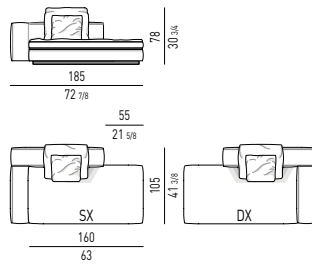

ELEMENTO TERMINALE PENISOLA CM 205 - SCHIENALE CM 150
OPEN-END ELEMENT WITH ARMREST CM 205 - BACKREST CM 150

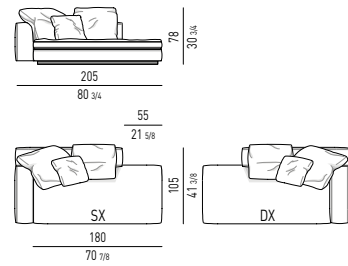

ELEMENTO TERMINALE PENISOLA CM 235 - SCHIENALE CM 155
OPEN-END ELEMENT WITH ARMREST CM 235 - BACKREST CM 155

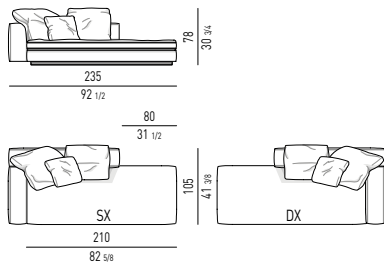

ELEMENTO TERMINALE PENISOLA CM 235 - SCHIENALE CM 180
OPEN-END ELEMENT WITH ARMREST CM 235 - BACKREST CM 180

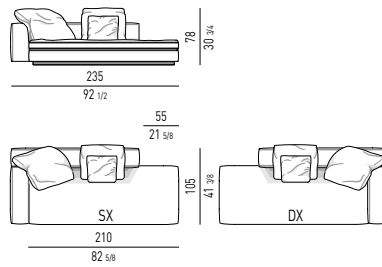

ELEMENTO TERMINALE PENISOLA CM 265 - SCHIENALE CM 185
OPEN-END ELEMENT WITH ARMREST CM 265 - BACKREST CM 185

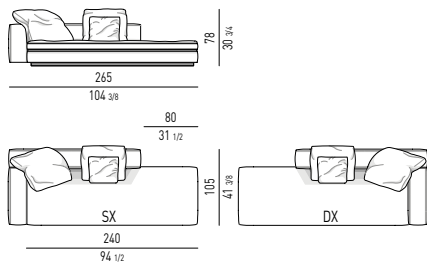

ELEMENTO TERMINALE PENISOLA CM 265 - SCHIENALE CM 210
OPEN-END ELEMENT WITH ARMREST CM 265 - BACKREST CM 210

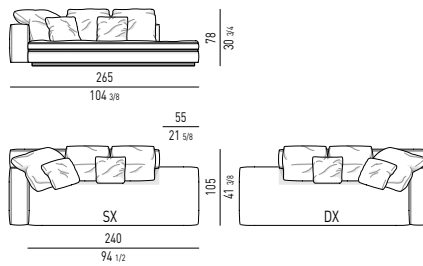

Minotti

ELEMENTI PENISOLA | OPEN-END ELEMENTS

ELEMENTO PENISOLA CM 160 - SCHIENALE CM 80
OPEN-END ELEMENT CM 160 - BACKREST CM 80

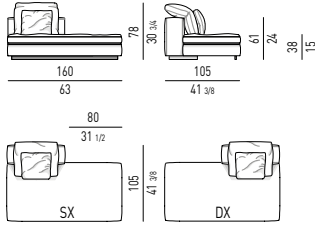

ELEMENTO PENISOLA CM 160 - SCHIENALE CM 105
OPEN-END ELEMENT CM 160 - BACKREST CM 105

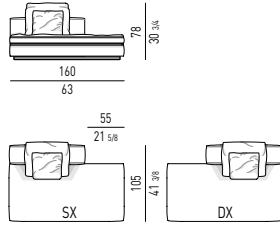

ELEMENTO PENISOLA CM 210 - SCHIENALE CM 130
OPEN-END ELEMENT CM 210 - BACKREST CM 130

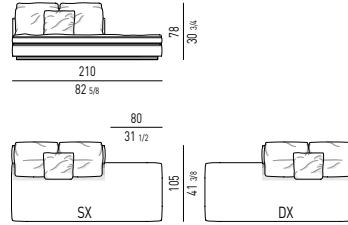

ELEMENTO PENISOLA CM 210 - SCHIENALE CM 155
OPEN-END ELEMENT CM 210 - BACKREST CM 155

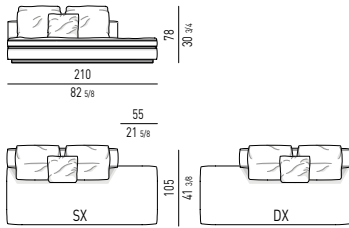

ELEMENTO PENISOLA CM 240 - SCHIENALE CM 160
OPEN-END ELEMENT CM 240 - BACKREST CM 160

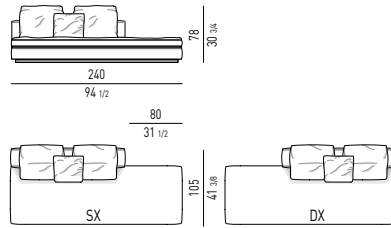

ELEMENTO PENISOLA CM 240 - SCHIENALE CM 185
OPEN-END ELEMENT CM 240 - BACKREST CM 185

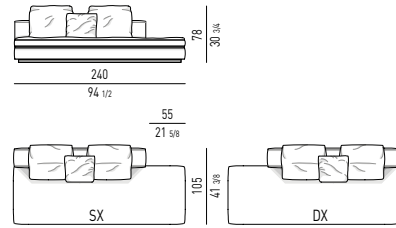

ELEMENTI CENTRALI | CENTRAL ELEMENTS

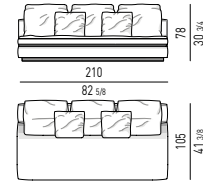
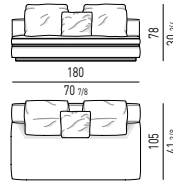
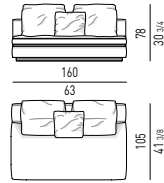
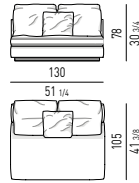
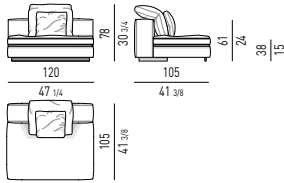

COUCH

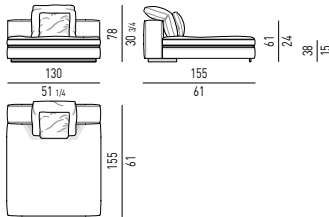

Minotti

CHAISE-LONGUE

CHAISE-LONGUE CM 105X185 - BRACCIOLO CM 80
CHAISE-LONGUE CM 105X185 - ARMREST CM 80

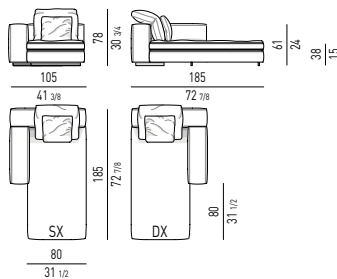

CHAISE-LONGUE CM 155X155 - BRACCIOLO CM 80
CHAISE-LONGUE CM 155X155 - ARMREST CM 80

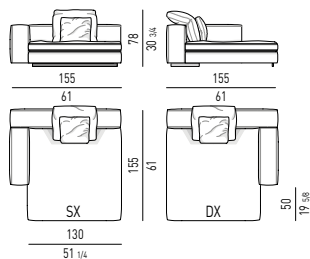

CHAISE-LONGUE CM 155X155 - BRACCIOLO CM 130
CHAISE-LONGUE CM 155X155 - ARMREST CM 130

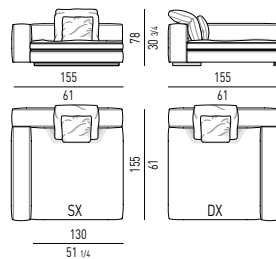

POUF | OTTOMANS

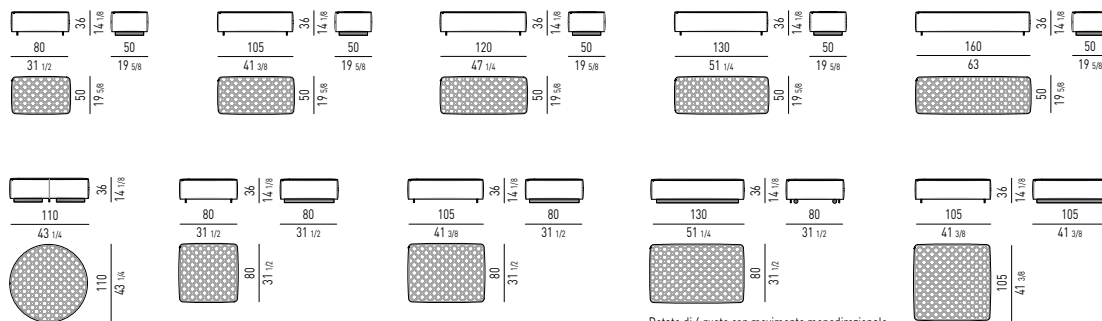

Dotato di 4 ruote con movimento monodirezionale
With 4 one-way motion casters

POGGIATESTA OPTIONAL "YANG"
"YANG" OPTIONAL HEADREST

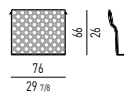

CUSCINO SCHIENALE OPTIONAL "YANG"
"YANG" OPTIONAL BACKREST CUSHION

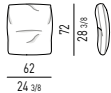

CUSCINO OPTIONAL "YANG"
"YANG" OPTIONAL CUSHION



RULLO OPTIONAL "YANG"
"YANG" OPTIONAL ROLL

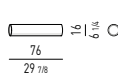

ELEMENTI "OFFSET" | "OFFSET" ELEMENT

"OFFSET" ELEMENTI PENISOLA | "OFFSET" OPEN-END ELEMENTS

"OFFSET" ELEMENTO PENISOLA CM 235 - SCHIENALE CM 155
"OFFSET" OPEN-END ELEMENT CM 235 - BACKREST CM 155

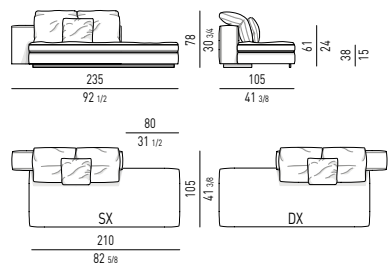

"OFFSET" ELEMENTO PENISOLA CM 235 - SCHIENALE CM 180
"OFFSET" OPEN-END ELEMENT CM 235 - BACKREST CM 180

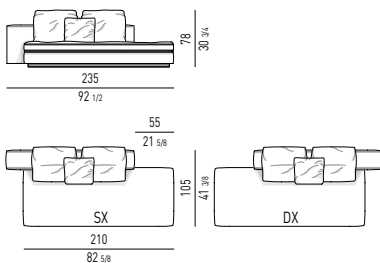

"OFFSET" ELEMENTO PENISOLA CM 265 - SCHIENALE CM 195
"OFFSET" OPEN-END ELEMENT CM 265 - BACKREST CM 195

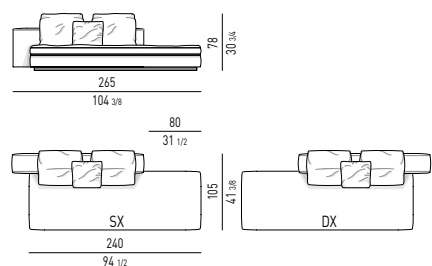

"OFFSET" ELEMENTO PENISOLA CM 265 - SCHIENALE CM 210
"OFFSET" OPEN-END ELEMENT CM 265 - BACKREST CM 210

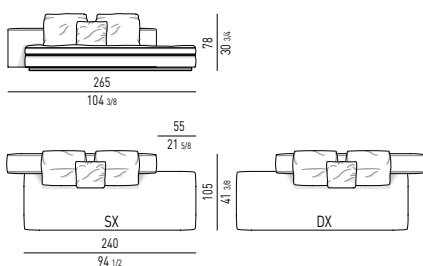

"OFFSET" ELEMENTI CENTRALI | "OFFSET" CENTRAL ELEMENT

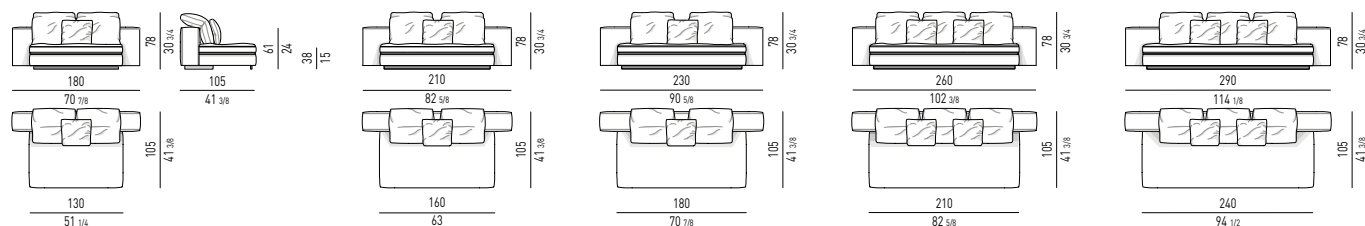

"OFFSET" TERMINALI CON BRACCIOLO | "OFFSET" ELEMENTS WITH ONE ARMREST

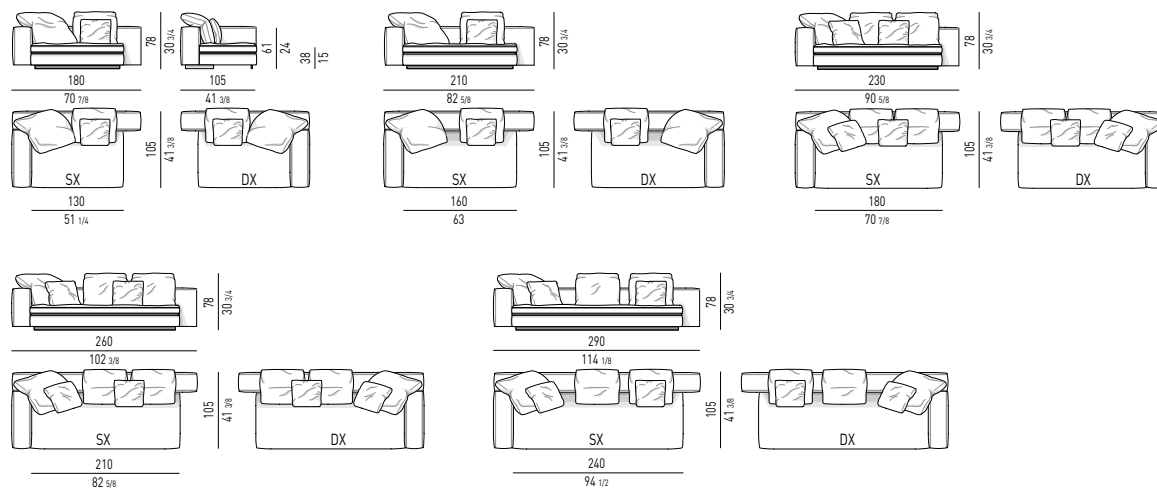

Minotti

"OFFSET" TERMINALI SENZA BRACCIOLO | "OFFSET" ELEMENTS WITHOUT ARMREST

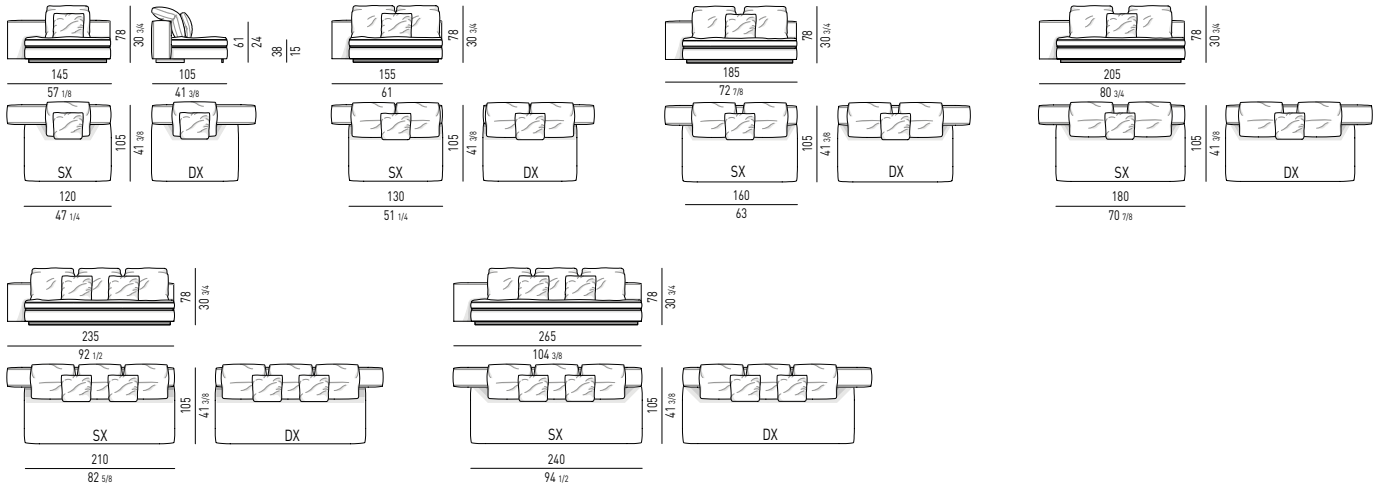

"OFFSET" DAYBED

"OFFSET" DAYBED CM 260 - SCHIENALE CM 180
"OFFSET" DAYBED CM 260 - BACKREST CM 180

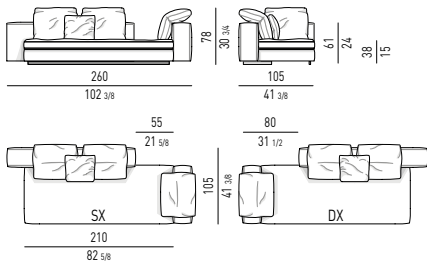

"OFFSET" DAYBED CM 290 - SCHIENALE CM 185
"OFFSET" DAYBED CM 290 - BACKREST CM 185

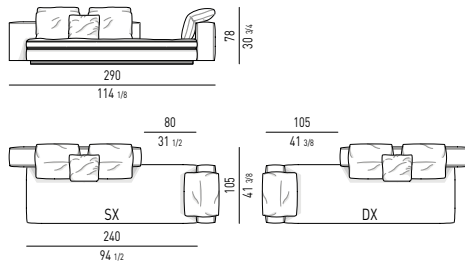

"OFFSET" COUCH

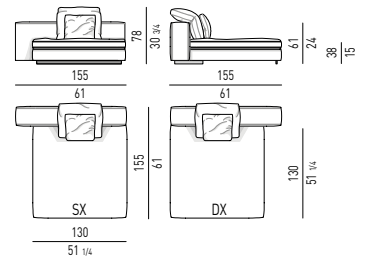

POUF | OTTOMANS

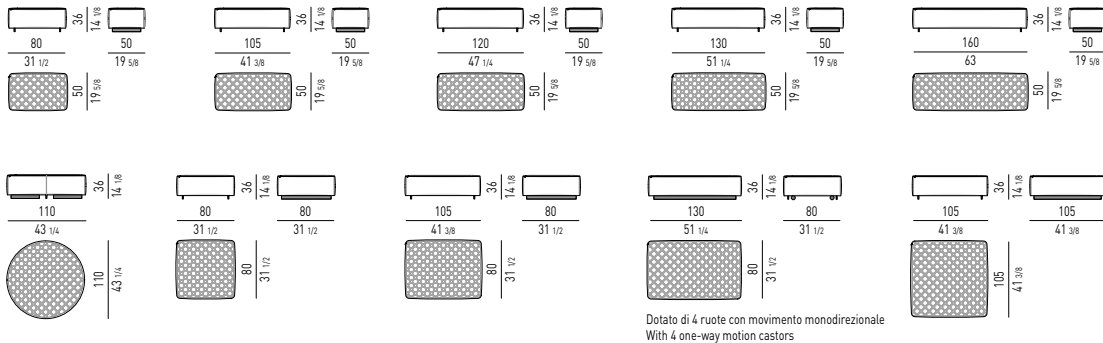

POGGIATESTA OPTIONAL "YANG"
"YANG" OPTIONAL HEADREST

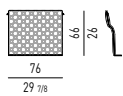

CUSCINO SCHIENALE OPTIONAL "YANG"
"YANG" OPTIONAL BACKREST CUSHION

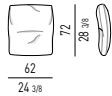

CUSCINO OPTIONAL "YANG"
"YANG" OPTIONAL CUSHION



RULLO OPTIONAL "YANG"
"YANG" OPTIONAL ROLL

